

Measurement of a Circularly Polarized Patch Antenna at 1.5 GHz

By Evan Wahlin

Instructor: Dr. Raymond Kwok

Table of Contents

Abstract	3
Introduction and Theory	3
Equations	8
Construction	10
Equipment	12
Procedure	14
Results	18
Conclusions	32
Further Work	33
References	34
Appendix A – Data Tables	35

Abstract

In this lab my goal was to build a circularly polarized patch antenna. This was done using a copper ground plate and plastic spacers to separate the ground from the patch. The antenna was to be measured using a constructed dipole antenna and a Hewlett Packard 8753C Network Analyzer.

A patch antenna can be circularly polarized by modifying the patch. The modification can be done in several ways, including cutting a slot or a corner off, which disrupts the radiation pattern. I decided to cut out a square corner. Because I did not know how large of a corner to cut out, I decided to experiment with three different cutout sizes and determine which gave the best polarization. Construction failed on one of the antennas, but the other two were made with cutouts of approximately 1cm x 1cm and 4cm x 4cm. Polarization was observed on both of them but was much more pronounced on the antenna with the larger cutout.

Introduction and Theory

Linear Polarization

To understand what one means by circular polarization, it is first important to understand the simplest classic model of an electromagnetic wave. Solutions to Maxwell's equations can come in many forms but one of the simplest is a traveling electromagnetic wave, with the electric field and magnetic fields orthogonal to each other, but individually varying only in one vector direction [6]. A normal rectangular patch antenna produces this type of radiation [5]. A visualization of such a wave is shown below.

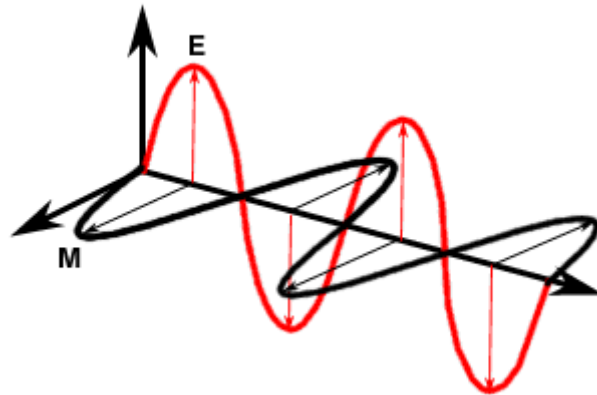

Figure 1: Linear Polarized EM Wave

Circular Polarization

Linear polarization represents the simplest form of electromagnetic wave. However it is also rare to find a completely linearly polarized wave in nature. In reality most electromagnetic waves are circularly polarized.

This is because the solutions to Maxwell's equations also allow for the possibility of electromagnetic fields and magnetic fields which, while still orthogonal to each other, are functions in time of sine and cosine with respect to a particular vector direction. The result is that the waves rotate as a function of time as well as travel in a particular vector direction [6]. A visualization of this is shown below.

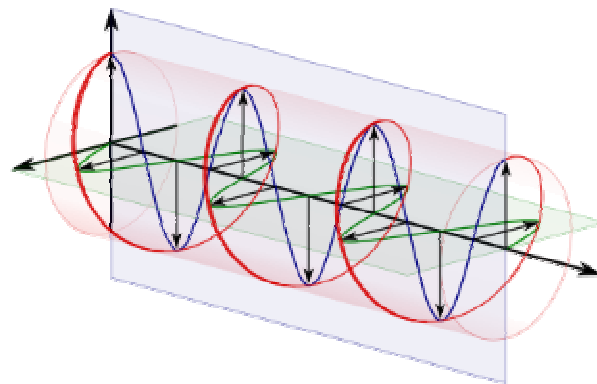

Figure 2: Circularly Polarized EM Wave

A common type of radiation is actually elliptical polarization. This is simply a form of circular polarization in which the electric field in one direction is not strictly equal to the electric field in the perpendicular direction [6].

The amount of polarization can therefore be determined by measuring the power, and by extension the magnitude of the electric field, using an antenna placed in two directions perpendicular to each other and also perpendicular to the direction in which the wave is travelling.

Antenna Theory

A patch antenna is simply a rectangular piece of conducting material placed above a ground, similar to a microstrip. The wavelength of radiation is determined by the length of the patch. The figure below shows the diagram of a sample patch, in this case excited by an input microstrip.

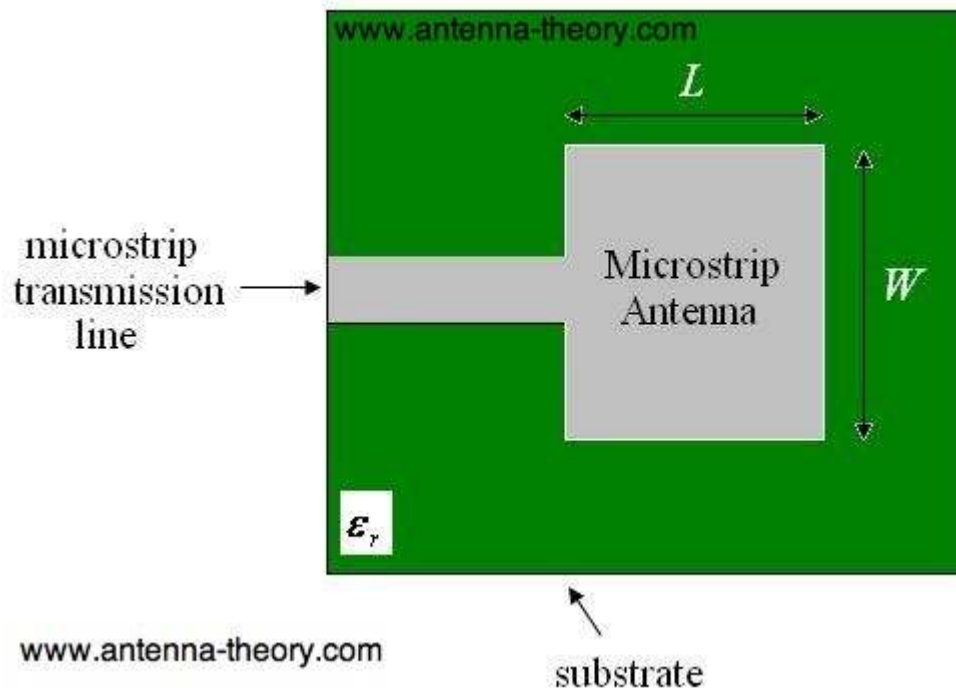

Figure 3: Example Patch (Microstrip) Antenna [5]

The figure below can be used to explain how an antenna radiates. The patch antenna is roughly equivalent to an open circuited transmission line. With a reflection coefficient of -1, this means the voltage is maximum at the end of the antenna (the +y direction in this diagram). Because the length of the antenna is designed to be half a wavelength, approximately, the voltage is minimum at the front end of the antenna (the -y side in this diagram). This creates fringing fields as shown in the figure. [5]

These fringing fields are what cause the antenna to radiate. Right at the surface of the patch, the y-component of the electric fields are the same whether at the front end or the rear end of the patch. Because they are the same, they reinforce each other. It is these fringing fields which are responsible for the radiation. There is also a current distribution in the patch but it is cancelled by an opposite current distribution in the ground plane, producing no radiation. [5]

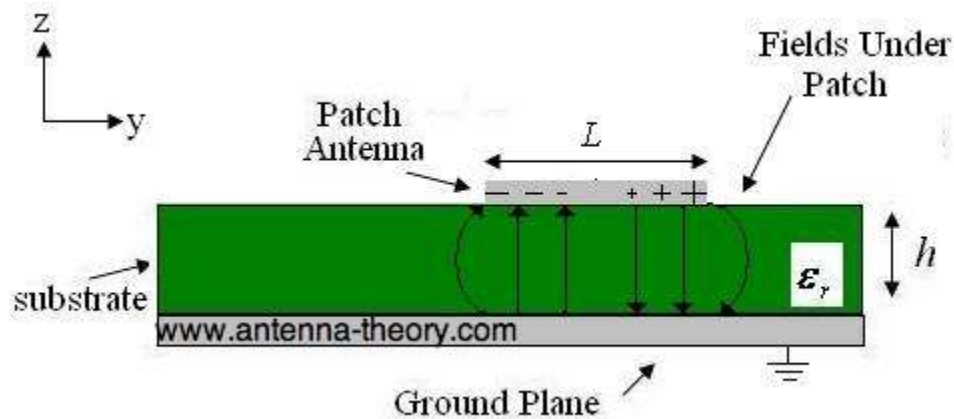

Figure 4: Fringing Fields in Patch Antenna [5]

Directivity and Radiation Pattern

The radiation pattern of a standard patch antenna looks similar to that shown below in figure 5. The ideal pattern is roughly hemispherical in nature. The bottom half of the sphere is ideally zero because it is beneath the ground plane where electric fields cannot radiate. There is also a small pinch in the radiation pattern corresponding to the dimension in the patch where the voltage is zero, roughly halfway along the length of the patch (see figure 4).

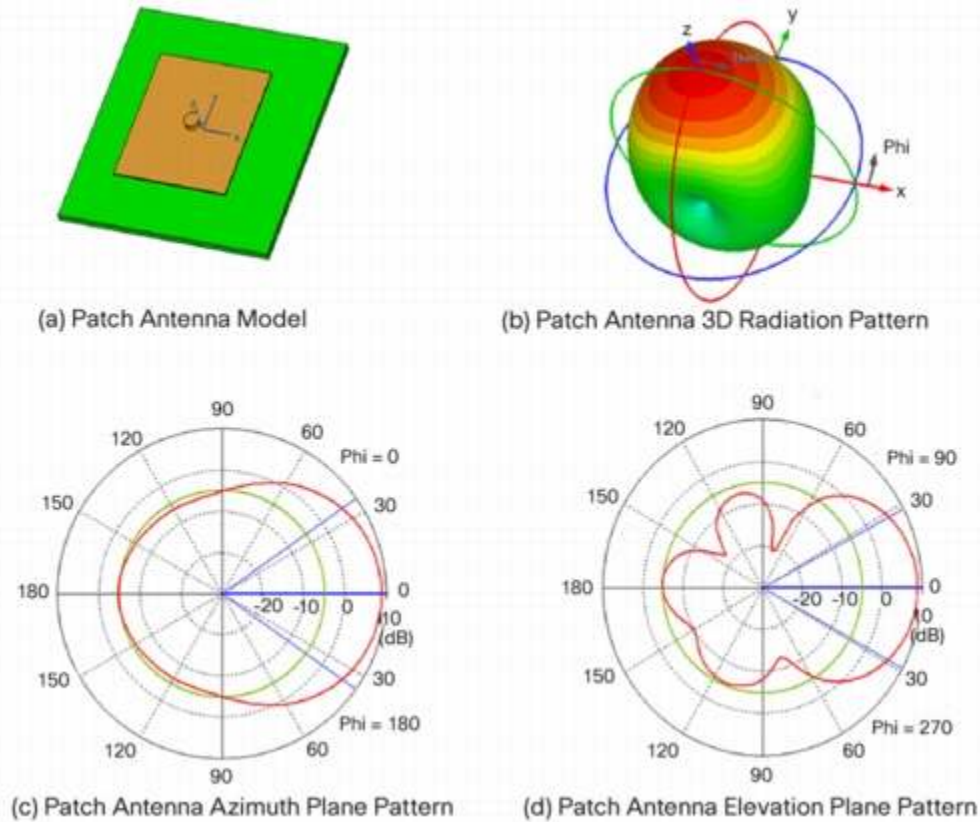

Figure 5: Normal Radiation Pattern for Patch Antenna [1]

The strict definition of directivity is the amount of power in a particular direction as a fraction of the total average power radiated by a similar antenna that radiates equally in all directions. In simpler terms this can be thought of as how “focused” an antenna is. For a patch antenna, the radiation is roughly evenly distributed through a hemisphere, making it not a very directive antenna. [1]

Circularity

Circularity can be achieved in many ways. One of these ways, for example, is to feed the antenna with two different lines, one phase shifted by 90 degrees from the other [5]. Another way is to perturb the dimensions of the patch. By perturbing the patch, the current distribution is altered, altering the voltage distribution and the fringing fields and potentially allowing for circular polarization [5]. Different ways of perturbing the patch geometry are shown below. For

my project I decided to cut out a corner, similar to the “tab” method showing in diagram (II) in the figure below. [2]

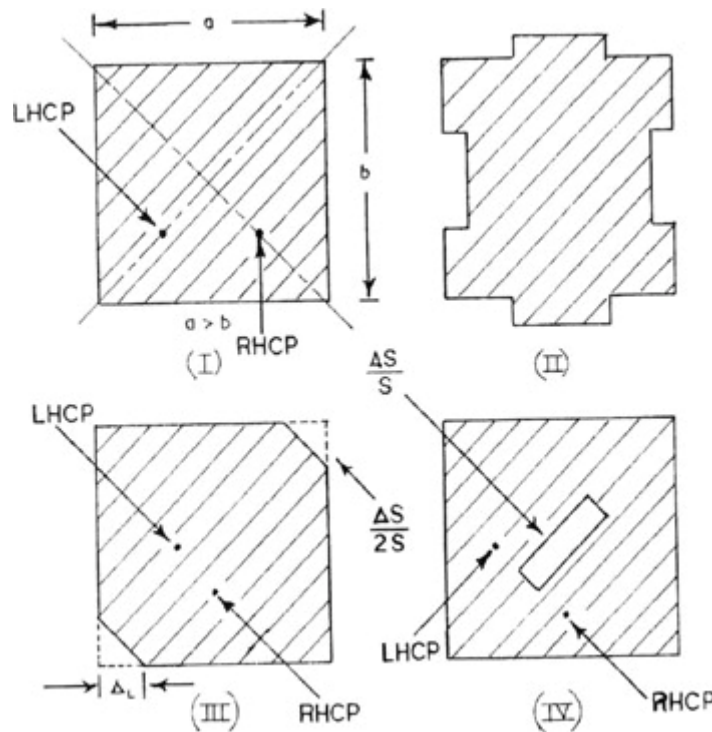

Figure 6: Circularly Polarized Patch Antennae [2]

Equations

The following equations describe how the geometry of a patch can be determined for a particular frequency. Equation 1 shows a simple model, which shows that the length of a patch antenna should be approximately equal to half of a wavelength, as described above. [4]

Equation 1: Approximate Frequency

$$f_c \approx \frac{c}{2L\sqrt{\epsilon_r}} = \frac{1}{2L\sqrt{\epsilon_0\epsilon_r\mu_0}}$$

However, more precise equations can be used. The following six equations describe how the dimensions of a patch can be determined. Of note is the fact that the effective length of a patch has to be modified by a factor of “delta L”. This is because of the complex geometry of the fringing field. The patch frequency is determined by the length of the patch plus an added amount to account for this field. [4]

Equation 2: Impedance of Antenna

$$Z_0 = \frac{120\pi h}{W \sqrt{\epsilon_{\text{eff}}}}$$

Equation 3: Effective Dielectric Constant:

$$\epsilon_{\text{eff}} = \frac{\epsilon_r + 1}{2} + \frac{\epsilon_r - 1}{2} \left(1 + \frac{12h}{W}\right)^{-1/2}$$

Equation 4: Delta L

$$\Delta l = 0.412h \left(\frac{\epsilon_{\text{eff}} + 0.3}{\epsilon_{\text{eff}} - 0.258} \right) \frac{(W/h) + 0.264}{(W/h) + 0.8}$$

Equation 5: Precise Antenna Frequency

$$f_r = \frac{c}{2\sqrt{\epsilon_{\text{eff}}}(L + 2 \Delta l)}$$

Equation 6: Delta + 2L

$$(L + 2 \Delta l) = \frac{\lambda_g}{2} = \frac{\lambda_0}{2\sqrt{\epsilon_{\text{eff}}}}$$

Equation 7: Antenna Width

$$W = \frac{c}{2f_r} \left(\frac{\epsilon_r + 1}{2} \right)^{-1/2}$$

Construction

The antennae were constructed using sheets of copper. A 2 foot X 1 foot sheet of copper was cut into thirds to obtain 3 pieces of copper each measuring 8 inches by 1 foot. These were to be used as the ground planes.

Smaller pieces of copper measuring 10.2cm wide were used to cut the antenna planes. Based on the desired frequency, using equations 4-7, the length of each was determined to be 9.4cm. One of the antennae was cut at 8.7cm by mistake, but this shifted the frequency by only about 100MHz.

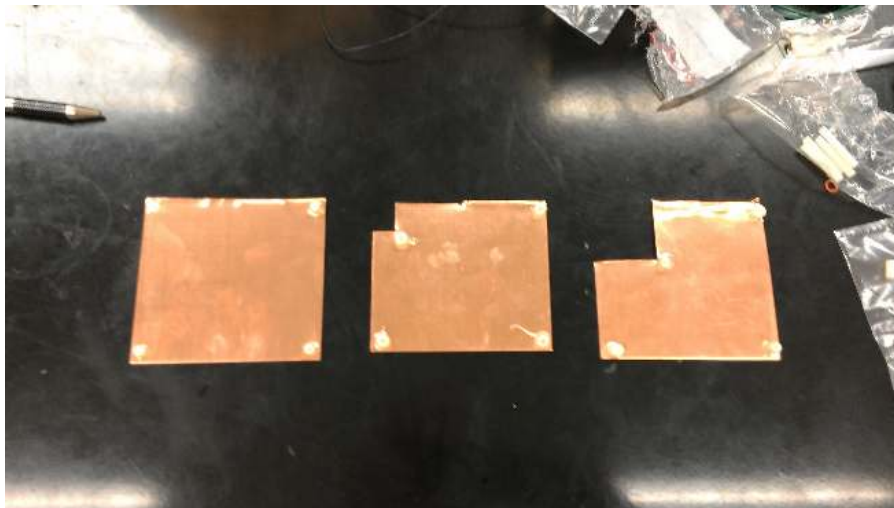

Figure 7: Three Patch Antennae Geometries

Holes were drilled in the ground planes in order to insert an N-type connector. The ground of the N connector was soldered or glued, ensuring good contact, to the ground plane. The center pin of the connector emerged 6mm beyond the ground plane. Plastic spacers were then cut measuring 6mm so that the antenna plane could be attached right at the level of the center pin on the N connector.

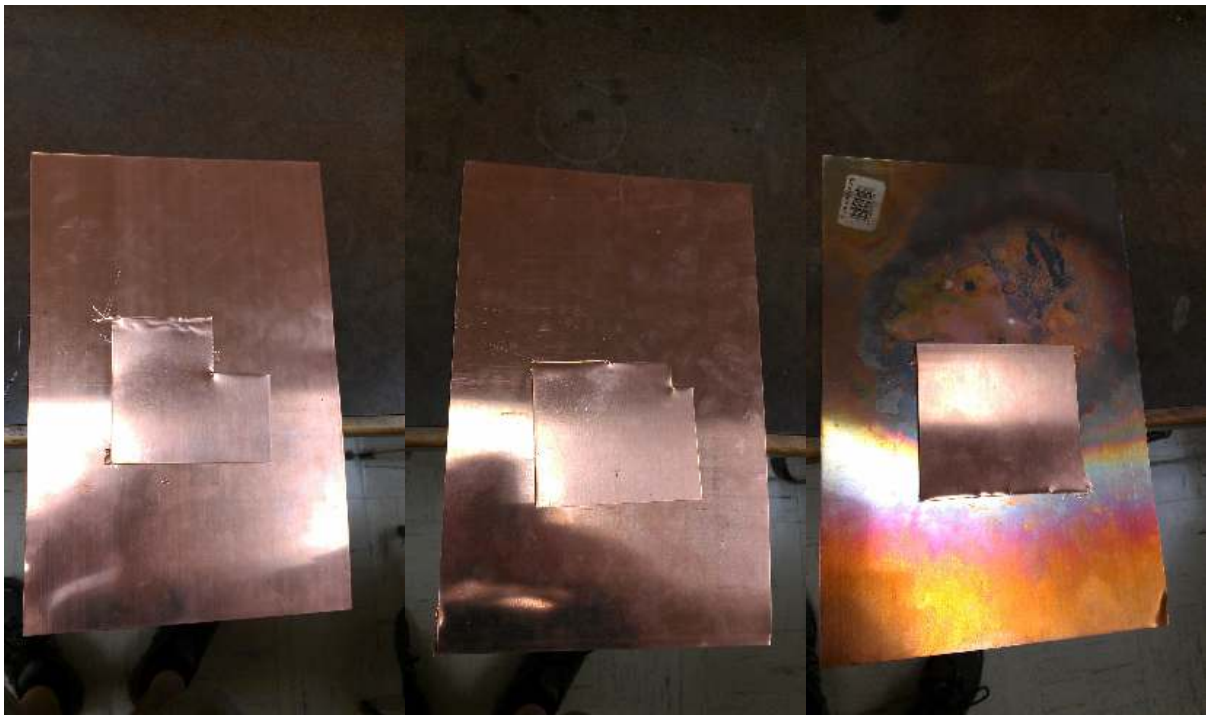

Figure 8: Assembled Antennae

At first it was decided to solder the center pin. However, experience with the ground plane showed that it was extremely difficult to solder to the copper, due to the inability to heat it to an appropriate temperature. The copper plane acts as a huge heat sink. When soldering the N connector to the ground plane, the copper had been put on a hot plate as my soldering iron could not get it hot enough. By the time the copper was hot enough to solder the N-type connector, it was burning and oxidizing. This was damaging it, and this method could not even be used to solder to the antenna plane due to the plastic spacers.

It was decided then to simply glue the antenna plane to the ground plane. The center pin on the conductor just barely made contact with the antenna plane, but measurements showed that it was making good contact and radiating well despite this.

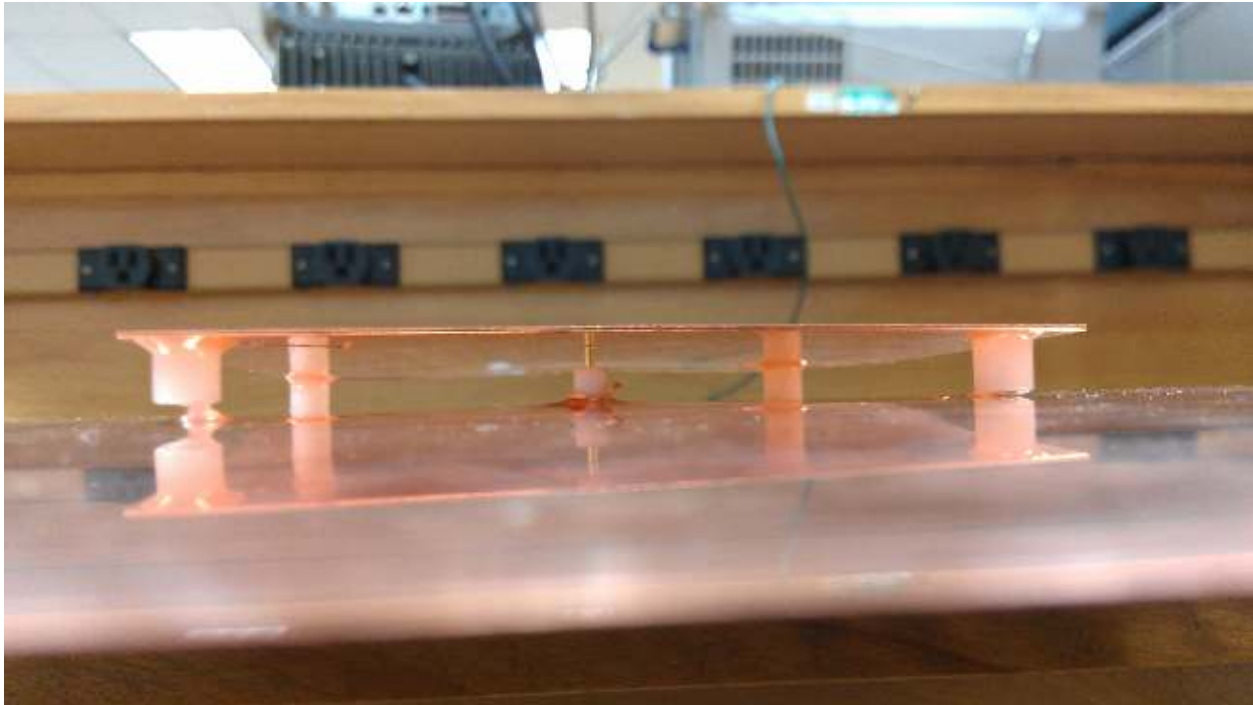

Figure 9: Antenna Feed Connection (N-type center pin)

This was not an ideal construction, but it allowed for measurements of the antennae and actually resulted in a very good return loss.

Equipment

The equipment used was:

3 - polished copper plates measuring 8 in. by 12 in

3 - polished copper plates measuring 10.2cm by 9cm

Soldering Iron

Plastic spacers

Hewlett Packard 8753C Network Analyzer

BNC and N-type cables and adapters

Dipole Antenna- 1.3GHz

The Equipment was connected in the following manner:

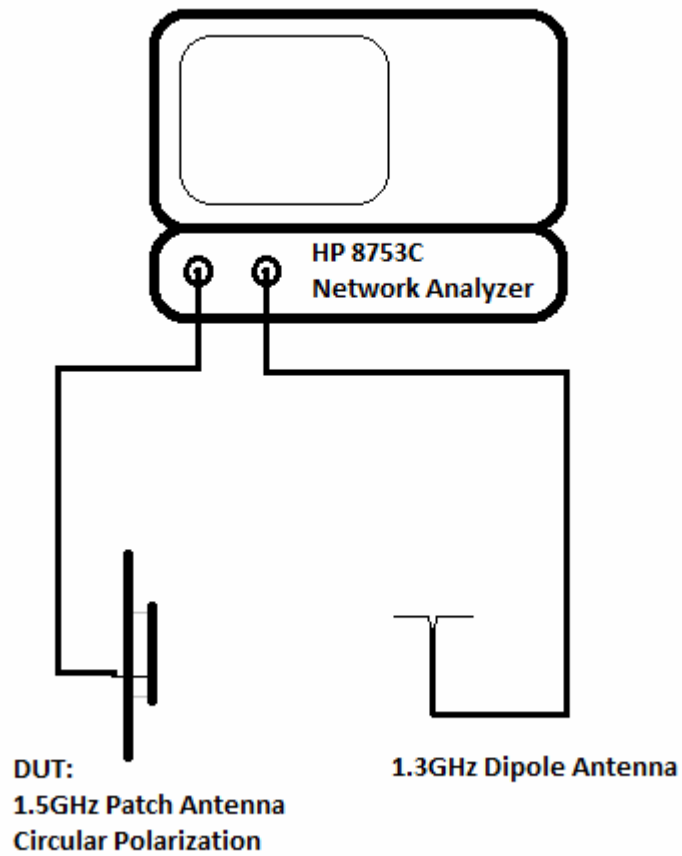

Figure 10: Equipment Connection

Procedure

Impedance Match

Before the antenna planes were glued to the ground plane, they had to be measured to ensure a good impedance match. This was done by connecting them to the equipment as shown in Figure 10. The network analyzer was set to measure the return loss, or the S11 parameter. This effectively meant that the connection of the dipole measuring antenna was irrelevant. The measurement would instead measure the power returned (bounced back) from the test antenna to port 1 of the network analyzer. Doing so not only ensured that maximum power would radiate from the antenna, but it was also used to determine exactly what frequency the antenna would ideally radiate.

Return loss then would ideally appear as a very low number, in the form of a negative spike on the network analyzer display. The amplitude of the return loss is not just affected by the frequency of excitation, but also by the impedance match between the patch antenna and the 50 ohm output of the network analyzer.

To achieve a good impedance match, the patch plane was slid very carefully across the ground plane, while continually maintaining contact with the center pin of the conductor. To ensure the frequency remained constant, the pin was kept along the axis of excitation. This axis was a line running down the center of the patch along the dimension which corresponded to the calculated value of “L” using the equations above and the construction process. As long as the conductor remained on this axis somewhat near the edge, the frequency would ideally stay constant.

As the patch was slid along the ground plane, the S11 negative spike was observed on the network analyzer. When the minimum value was achieved, representing the best possible impedance match, lines were marked on the ground plane and the patch plane was attached in that place using epoxy glue.

This procedure was repeated for the second antenna.

Radiation Measurement

Next, the goal was to measure the radiation pattern of both antennae. In doing so, two objectives were achieved: measurement of the overall shape of the radiation pattern, and also a measurement of the circularity of the emitted radiation.

Ideally, the radiation pattern should be measured at every point in space. This is of course an impossibility. Therefore the symmetrical nature of the pattern had to be taken advantage of. To gain a complete picture, the pattern had to be measured in two dimensions, similar to figure 5. The third dimension, consisting of an arc around the “z” axis in that picture, was unnecessary. This is because the points on that arc would all be in the same plane as the ground plane, meaning that the measurements would all be roughly minimal. This would not yield useful information about the radiation pattern.

The other two arcs, however, were important. Corresponding to the “y” direction in figure 5, measurements were made on a plane perpendicular to the axis of excitation. Measurements were also measured around a circle perpendicular to the direction perpendicular to the axis of excitation, corresponding to the “x” direction in figure 5.

Around the “y” direction, the pattern was measured every 10 degrees in a full 360 degree arc. It was determined from the measurements that behind the ground plane the radiation pattern was minimal. For that reason, around the “x” direction the radiation pattern was only measured for the 180 degree arc above the ground plane.

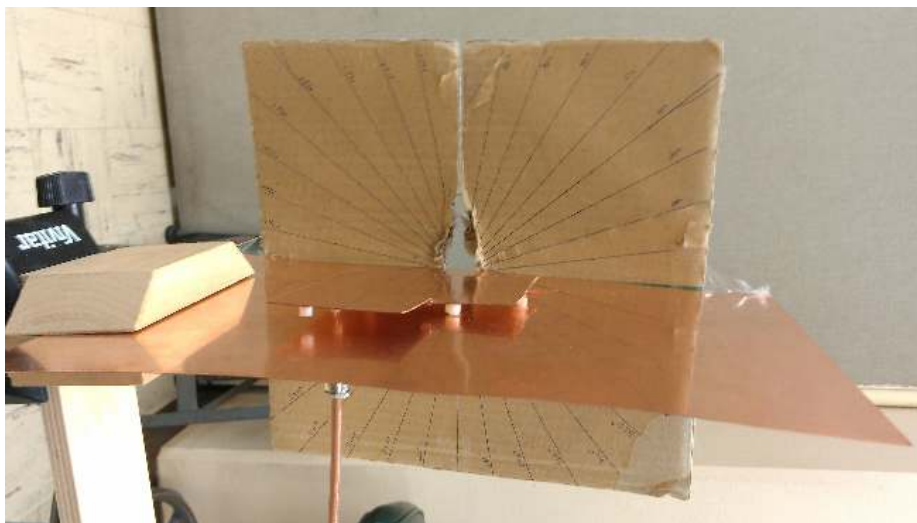

Figure 11: Angular Measurements

The measurement was performed using the 1.3 GHz dipole antenna. The network analyzer was set to measure S21, or the insertion loss from port 1 to port 2. With the dipole antenna connected to port 2 on the network analyzer, the amplitude measured on the network analyzer represented the transmitted power from the antenna. To ensure consistency of results, the antenna was held at a constant distance of 1.5 feet at every measurement point. A sample measurement is shown below. The marker in this figure is slightly off of the peak because the waveform as seen on the network analyzer was highly erratic.



Figure 12: Sample Radiation Power Measurement

Because of all of the sources of error involved, including the lack of accuracy from the uncalibrated network analyzer, the noise in the room, and the dipole antenna with a slightly different frequency, all of the measurements made were relative. This did not matter because the data of interest was the overall shape of the radiation pattern which could still be determined from relative power measurements.

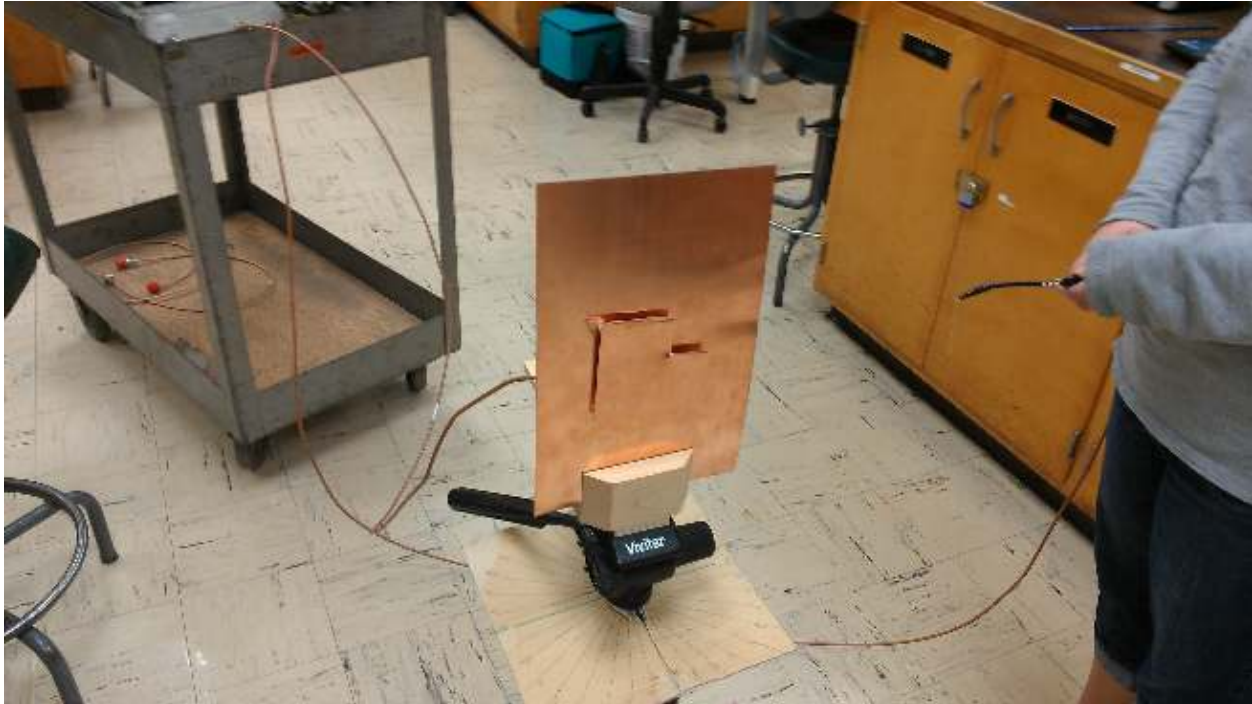

Figure 13: Test Environment

The other data of interest was the amount of circularity produced by the antenna. This was measured by rotating the dipole antenna by 90 degrees. In the previous measurements, the dipole was held parallel to the axis of excitation. This was because with a normal parallel polarized antenna, this is the direction the electric field would be moving as a radiated wave travelled away from the antenna. In order to pick up the power of such a wave using a dipole, the length of the copper would need to be oriented so that the electric field would excite the antenna along the maximum possible length.

By rotating the dipole antenna by 90 degrees, it could be shown that if the power measured in both orientations was equal or approximately equal, then the electric field coming off of the antenna was oriented in more than one direction. This would imply a circular polarization. Conversely, if the power measured in the 90 degree orientation was significantly less than the power measured in the parallel direction, it would show that the antenna was not very well circularly polarized.

This procedure was then repeated for the second antenna. The data was plotted in excel and the circularity was analyzed and plotted.

Results

Using the simple calculation of the frequency, a 1.5 GHz signal would require an antenna length of 10cm as shown below:

Table 1: Approximate Frequency Calculation

Length (m)	Frequency (GHz)
0.1	1.499

Using the more complex calculation, and the precise length of the cut antennae plane, the frequency was calculated to be 1.47 GHz as shown below:

Table 2: Precise Frequency Calculation – Larger Cutout Patch

Freq (Hz)	Epsilon Effective	Delta L (m)	Z0 (Ohms)	L + 2DeltaL (m)	W (m)
1.47E+09	1	0.0042005	22.18186567	0.101972789	0.101973

h (m)	L (m)	Lambda-0 (m)	Epsilon R	c (m/s)
0.006	0.0936	2.0395E-01	1	2.9980E+08

Using the more precise calculation for the shorter-cut antenna plane, the frequency was calculated to be 1.57 GHz as shown below:

Table 3: Precise Frequency Calculation – Smaller Cutout Patch

Freq (Hz)	Epsilon Effective	Delta L (m)	Z0 (Ohms)	L + 2DeltaL (m)	W (m)

1.57E+09	1	0.0041921	23.69083613	0.095477707	0.095478
----------	---	-----------	-------------	-------------	----------

h (m)	L (m)	Lambda-0 (m)	Epsilon R	c (m/s)
0.006	0.0871	1.9096E-01	1	2.9980E+08

The S11 parameter, also known as the return loss, for the antenna with the larger cutout is plotted below:

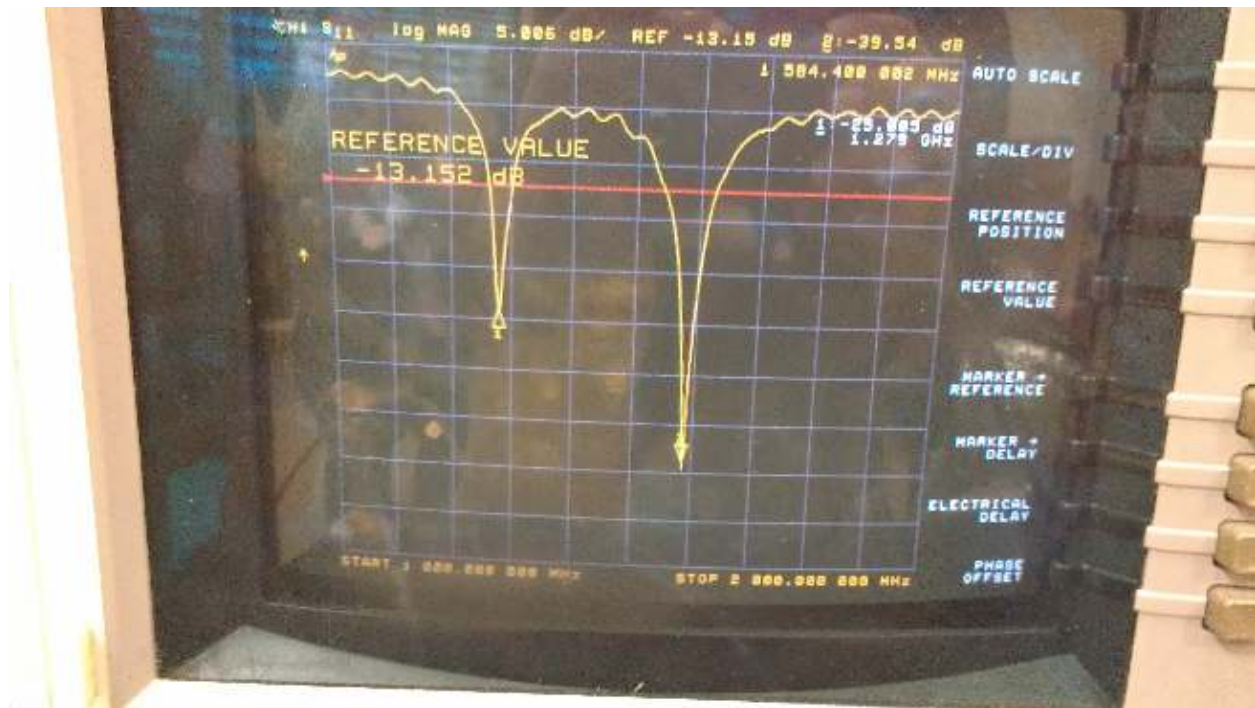

Figure 14: Return Loss Measurement (S11) – Larger Cutout Antenna

The results showed there were clearly two frequencies of interest for this antenna. This was a strong indicator of circular polarization. The first frequency was measured to be 1.28 GHz. It had a return loss of approximately 27 dB, which was an excellent result. This measurement was made by measuring the relative dB difference between the negative return loss spike, and the typical measured power for all other frequencies. In plainer language, it was

measured as the amplitude difference between the average level at the top of the waveform in figure 14 and the value of the negative spike in the same figure.

The main frequency was measured to be 1.504 GHz. This frequency deviated from the calculated value by 34 MHz, or approximately 2.5%. The return loss was measured to be approximately 35 dB, an even better result.

The S11 parameter for the second antenna with the smaller cutout is plotted below:

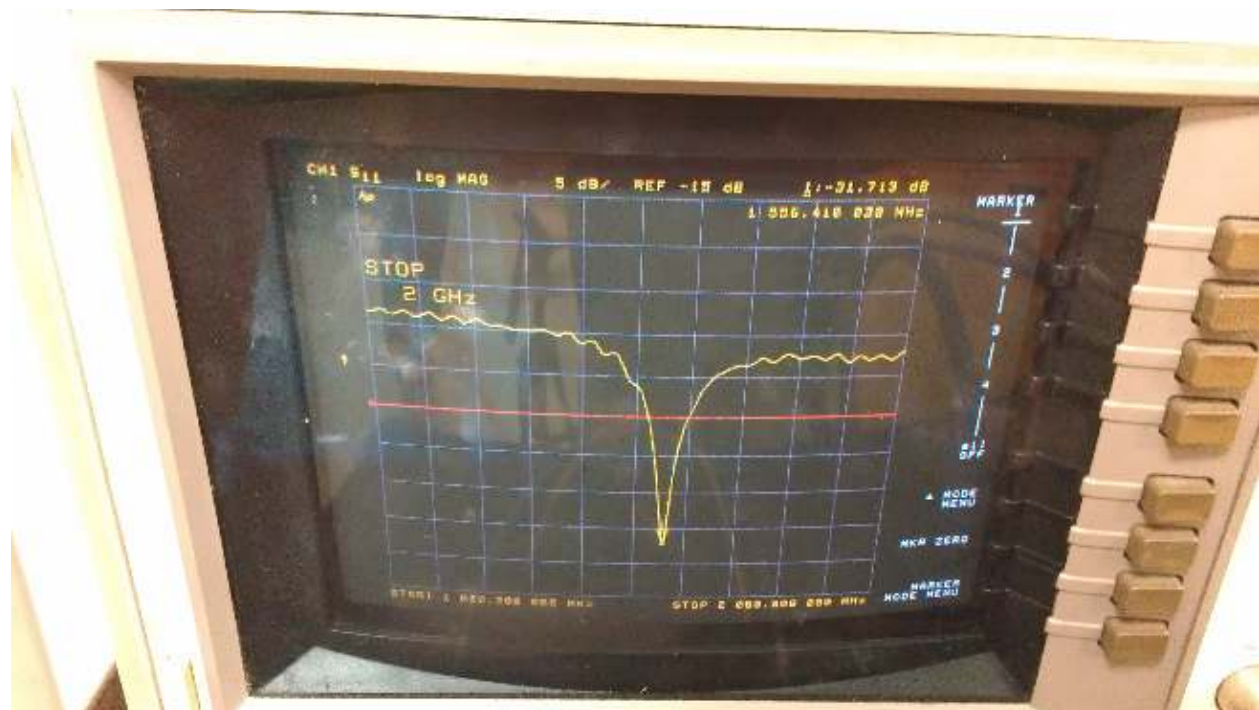

Figure 15: Return Loss (S11) Measurement – Smaller Cutout Antenna

The frequency was measured to be 1.556 GHz. This was a deviation of 14 MHz from the calculated value, or approximately 0.9%. The return loss was measured to be about 28 dB below the typical measured return loss for all frequencies using the same method as above.

The radiation pattern data was recorded in an excel spreadsheet (see appendix A for raw data values). Polar plots were then generated in excel. The following two graphs show the radiation pattern at frequency 1 of the antenna with the larger cutout, 1.28 GHz, the first plot being the 360 degree measurements in a plane perpendicular to the axis of excitation, and the second one being the measurements 180 degree around the plane parallel to the axis of excitation. In these plots the dipole antenna was held parallel to the axis of excitation,

representing the “normal” parallel polarized radiation. On the plot, 90 degrees represents a line pointing directly out the top of the antenna.

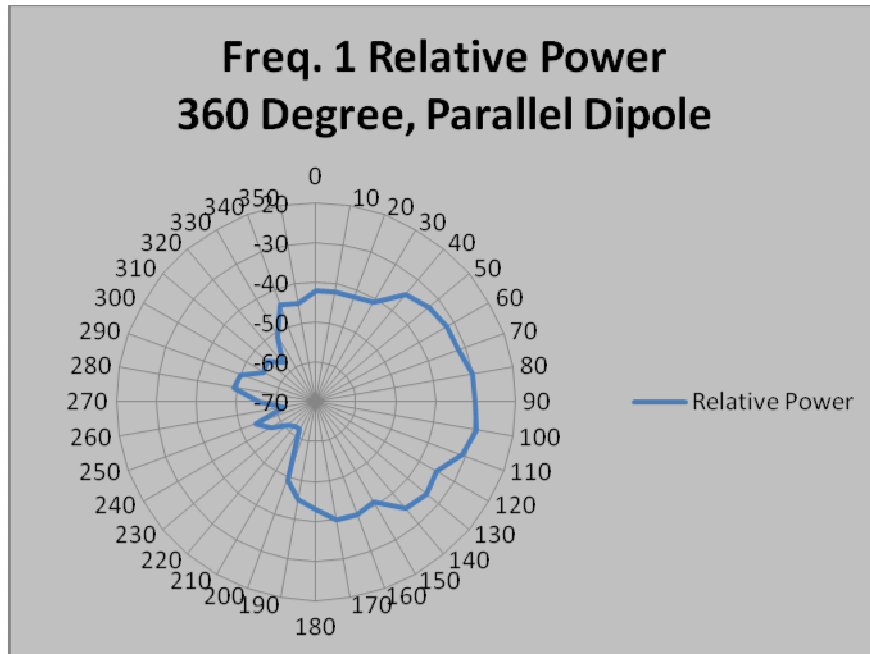

Figure 16: 360 Degree Power Measurement – Antenna:1 Freq.:1 Dipole:Parallel

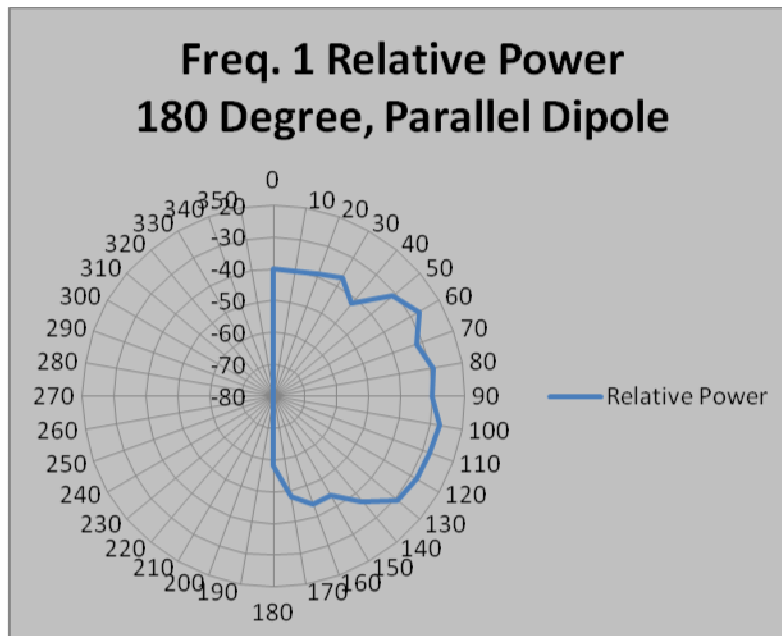

Figure 17: 180 Degree Power Measurement – Antenna:1 Freq.:1 Dipole:Parallel

The following two polar plots represent the same radiation patterns measured above but with the dipole antenna held in a perpendicular orientation, representing the “circularized” power of the emitted radiation.

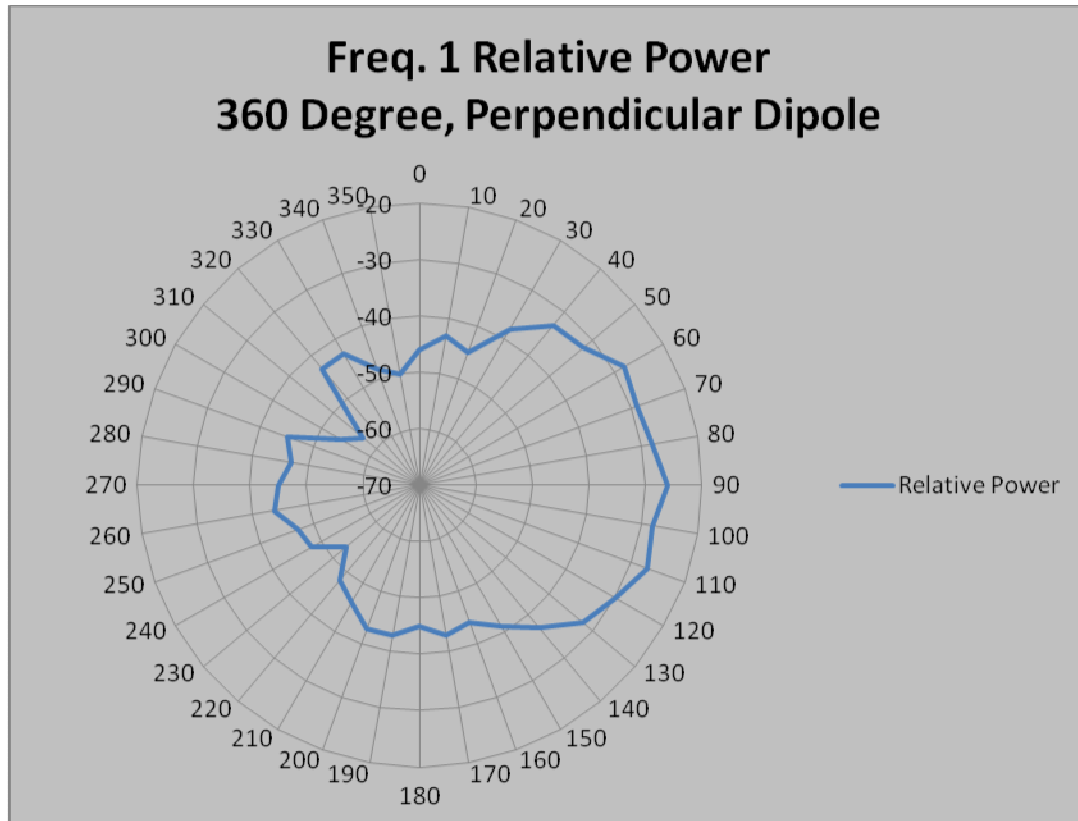

Figure 18: 360 Degree Power Measurement – Antenna:1 Freq.:1 Dipole:Perpendicular

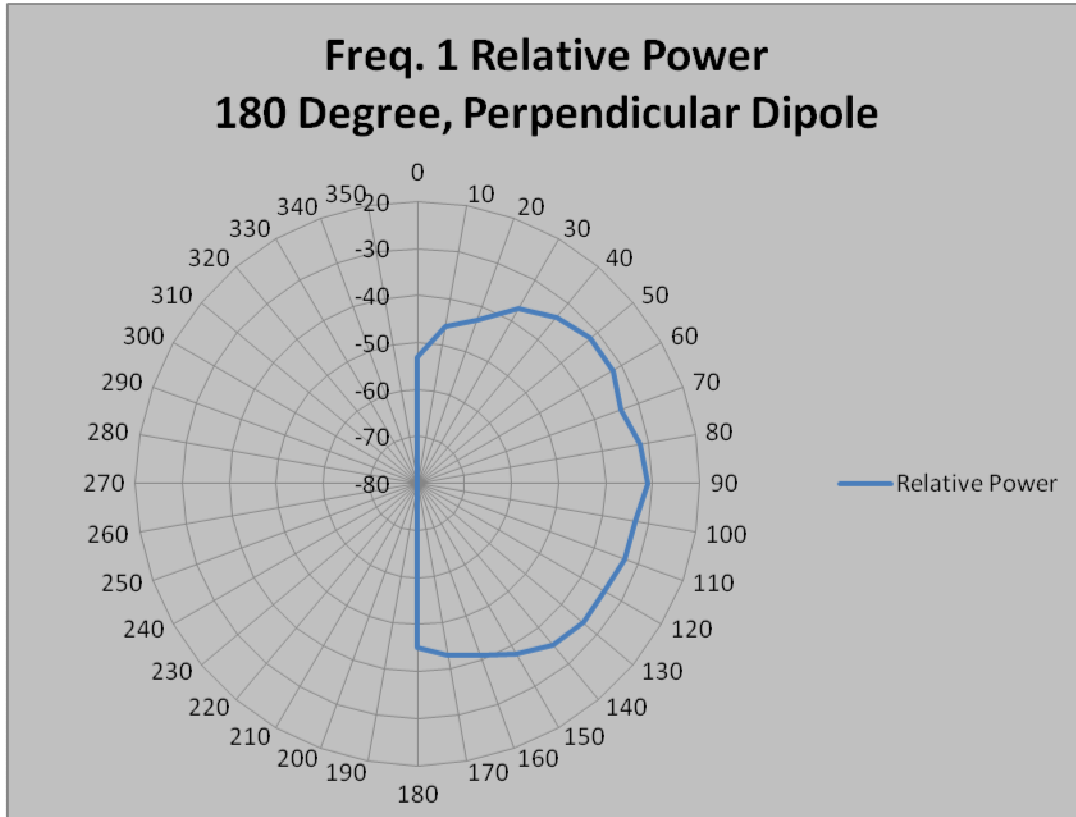

Figure 19: 180 Degree Power Measurement – Antenna:1 Freq.:1 Dipole:Perpendicular

The following four plots represent the same data for the second frequency (the main frequency of 1.5 GHz) on the first antenna with the larger cutout. The first two graphs represent the polar plots of the radiation pattern in the 360 degree dimension and the 180 degree dimension, respectively, with the dipole antenna in the parallel direction. The second two represent the same two measurements but with the dipole in the perpendicular (or circular measurement) direction.

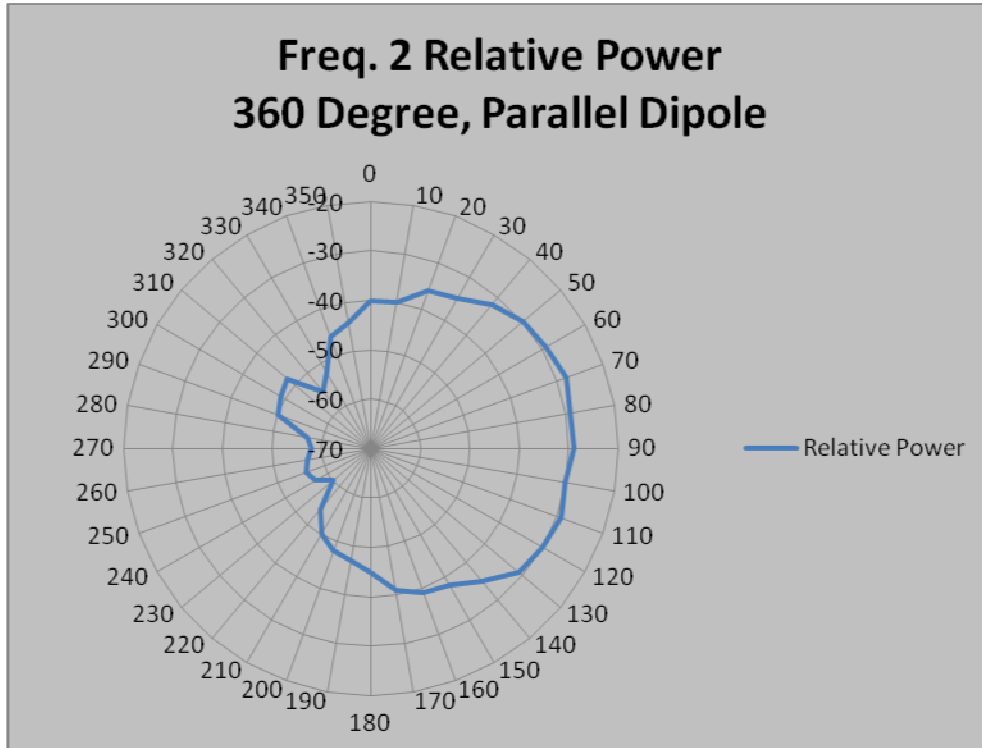

Figure 20: 360 Degree Power Measurement – Antenna:1 Freq.:2 Dipole:Parallel

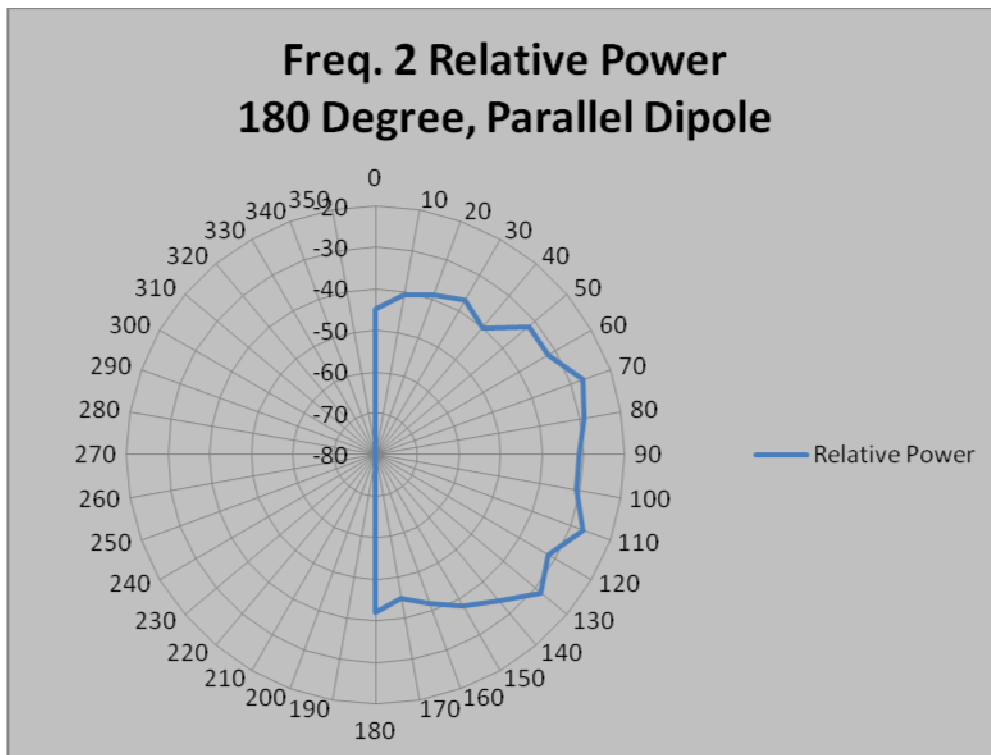

Figure 21: 180 Degree Power Measurement – Antenna:1 Freq.:2 Dipole:Parallel

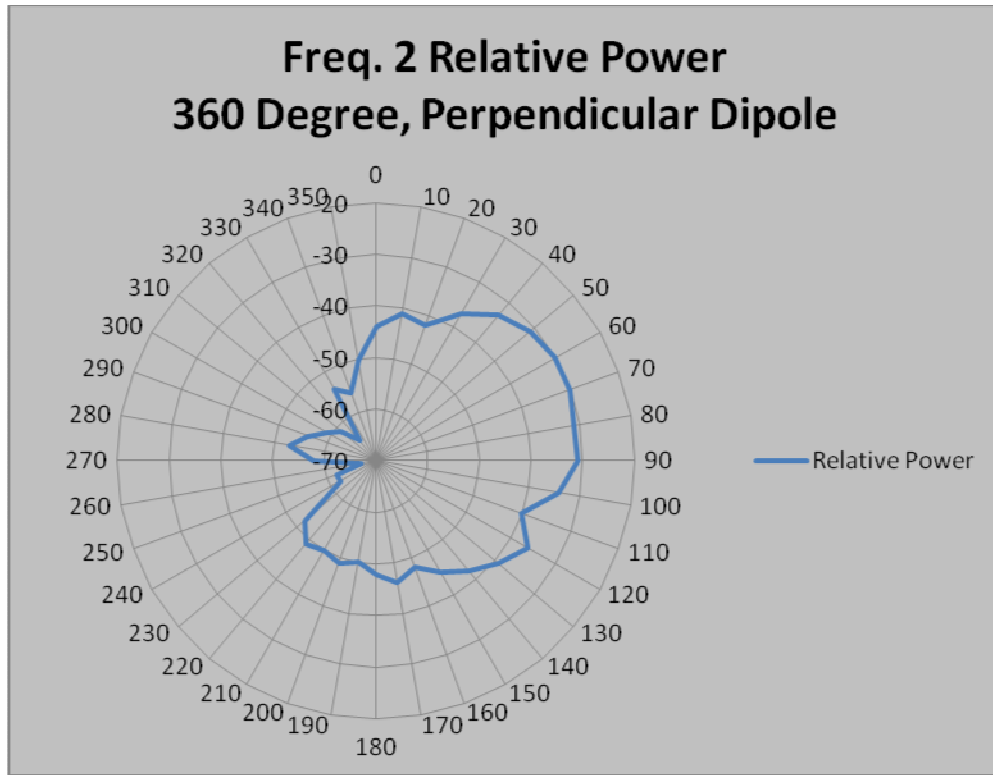

Figure 22: 360 Degree Power Measurement – Antenna:1 Freq.:2 Dipole:Perpendicular

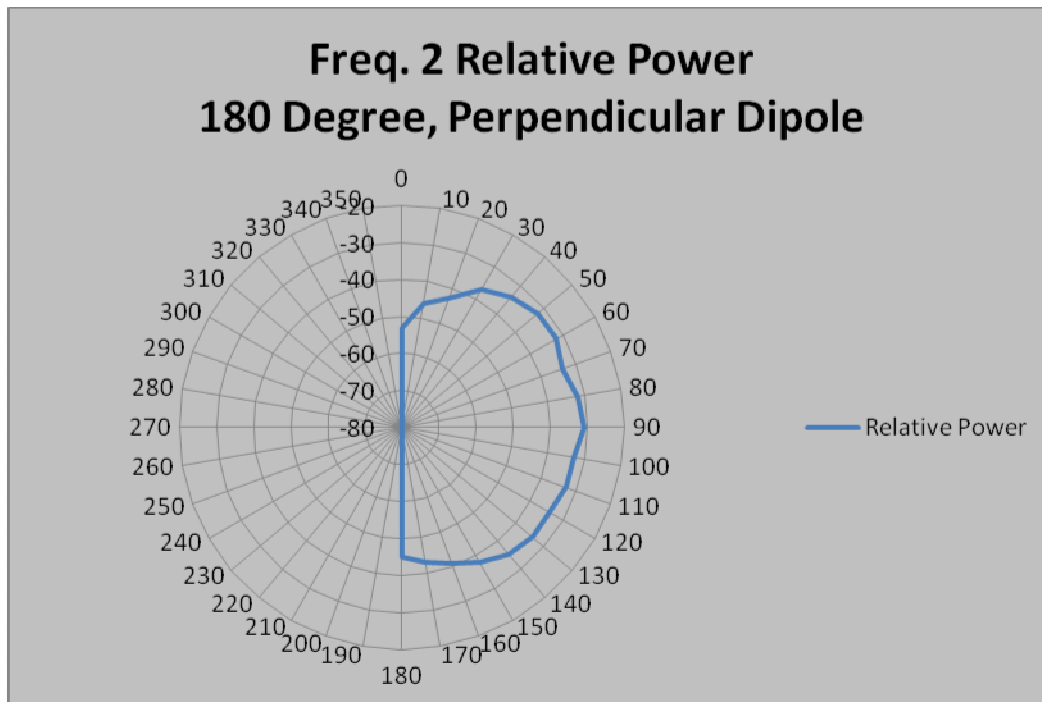

Figure 23: 180 Degree Power Measurement – Antenna:1 Freq.:2 Dipole:Perpendicular

The following four plots represent the same data for the second antenna (frequency of 1.5 GHz) with the smaller cutout. The first two graphs represent the polar plots of the radiation pattern in the 360 degree dimension and the 180 degree dimension, respectively, with the dipole antenna in the parallel direction. The second two represent the same two measurements but with the dipole in the perpendicular (or circular measurement) direction.

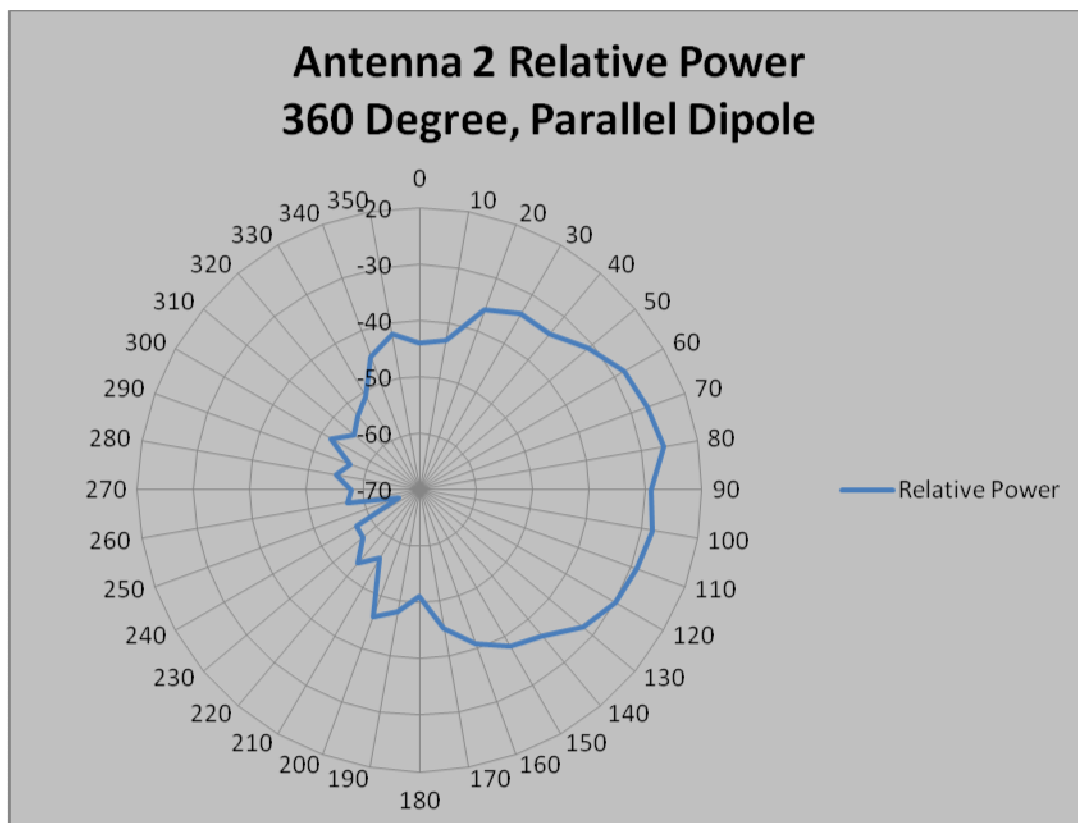

Figure 24: 360 Degree Power Measurement – Antenna:2 Dipole:Parallel

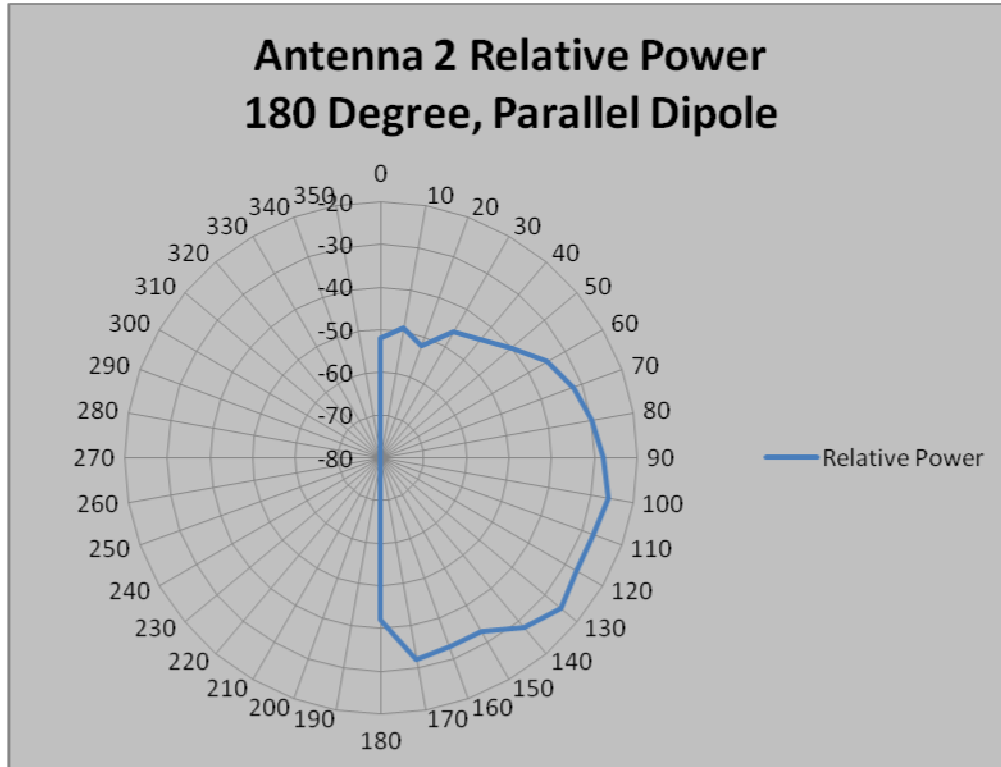

Figure 25: 180 Degree Power Measurement – Antenna:2 Dipole:Parallel

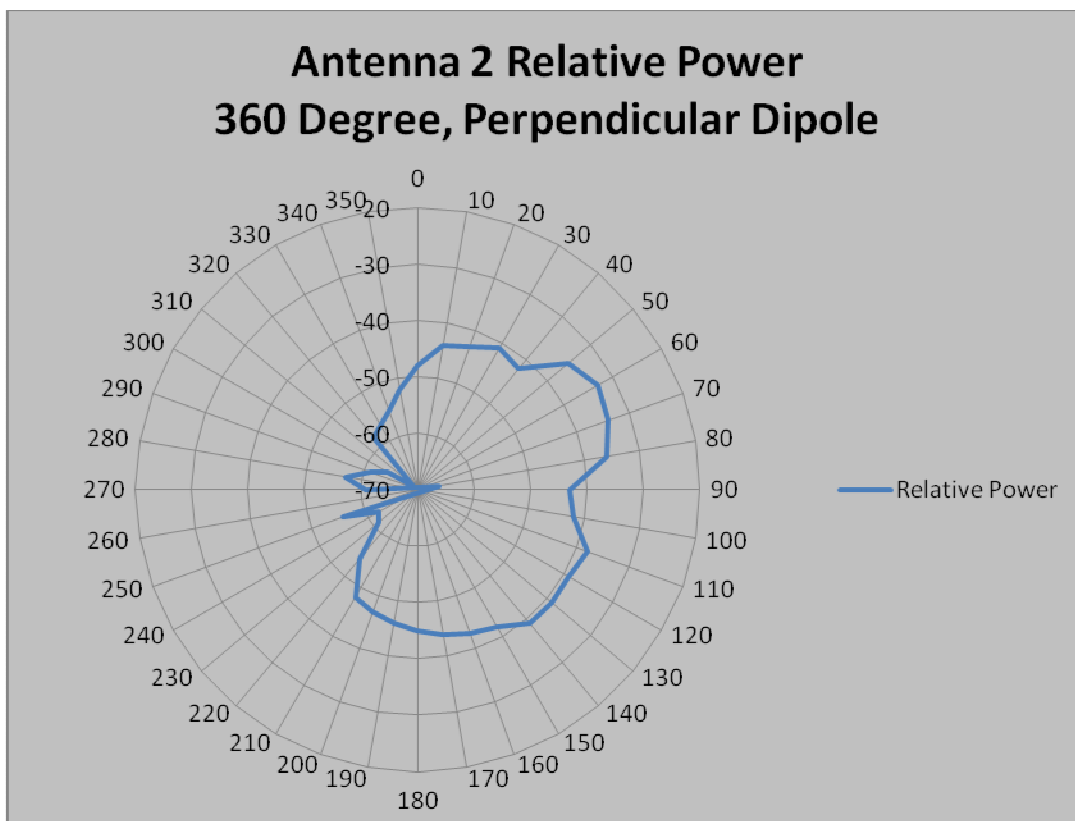

Figure 26: 360 Degree Power Measurement – Antenna:2 Dipole:Perpendicular

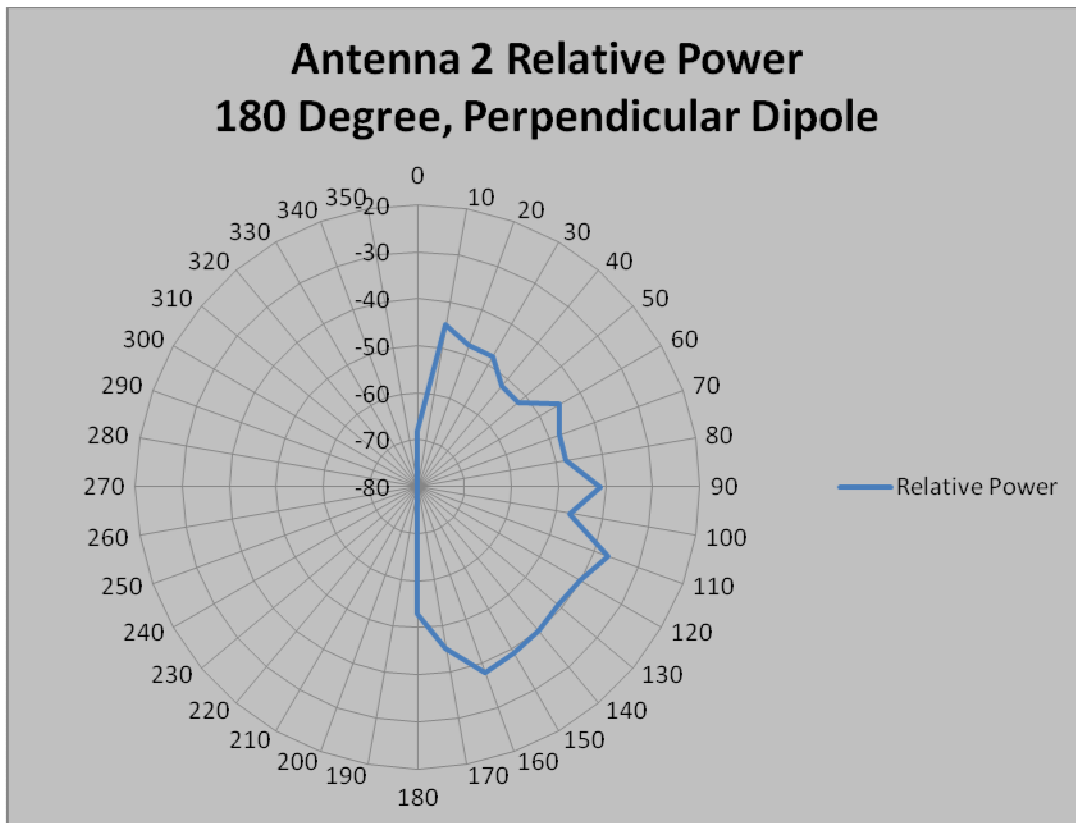

Figure 27: 180 Degree Power Measurement – Antenna:2 Dipole:Perpendicular

The above results show the general radiation pattern. From these results the amount of circularity can be inferred. In order to display the circularity more clearly, another analysis was performed. For every measurement made, the amplitude measured when the dipole was in the “parallel” position (parallel to the axis of excitation) was subtracted from the measurement made when the dipole was in the “perpendicular” position. If an antenna was perfectly circularly polarized, therefore, the measurements would be the same and the value would be calculated as “zero”. If an antenna was not very well circularized, the value would be negative meaning that the amplitude measured in the perpendicular direction was less than that in the parallel direction.

The calculated circular measurements were then plotted linearly. The graph below shows a plot of the circularity of both frequencies on the first antenna and the frequency of the second antenna, as measured in the 360 degree plane that was perpendicular to the axis of excitation.

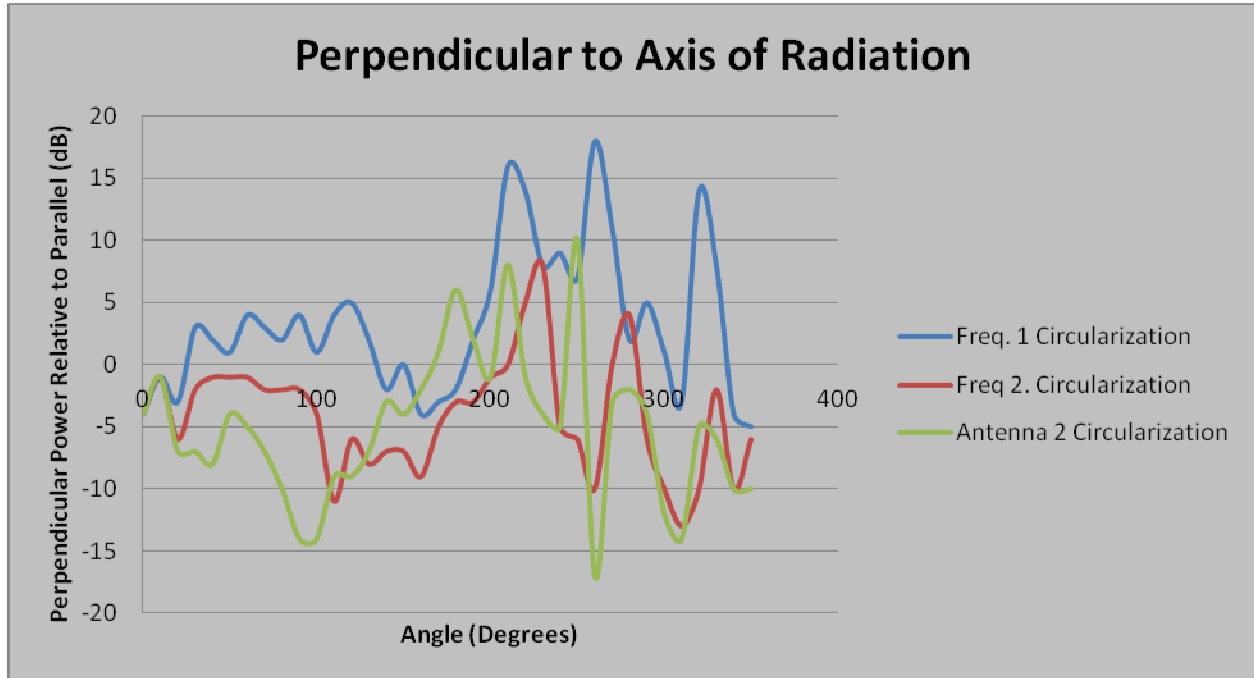

Figure 28: 360 Degree Measurement Circularity Graph

The right half of the graph was clearly very noisy. The reason for this was that those measurements represent the 180 degrees behind the antenna. Since those values were ideally zero, background and test equipment noise would affect the measurements a lot more. For this reason the focus was changed to the front 180 degrees of the antenna. This plot is shown below.

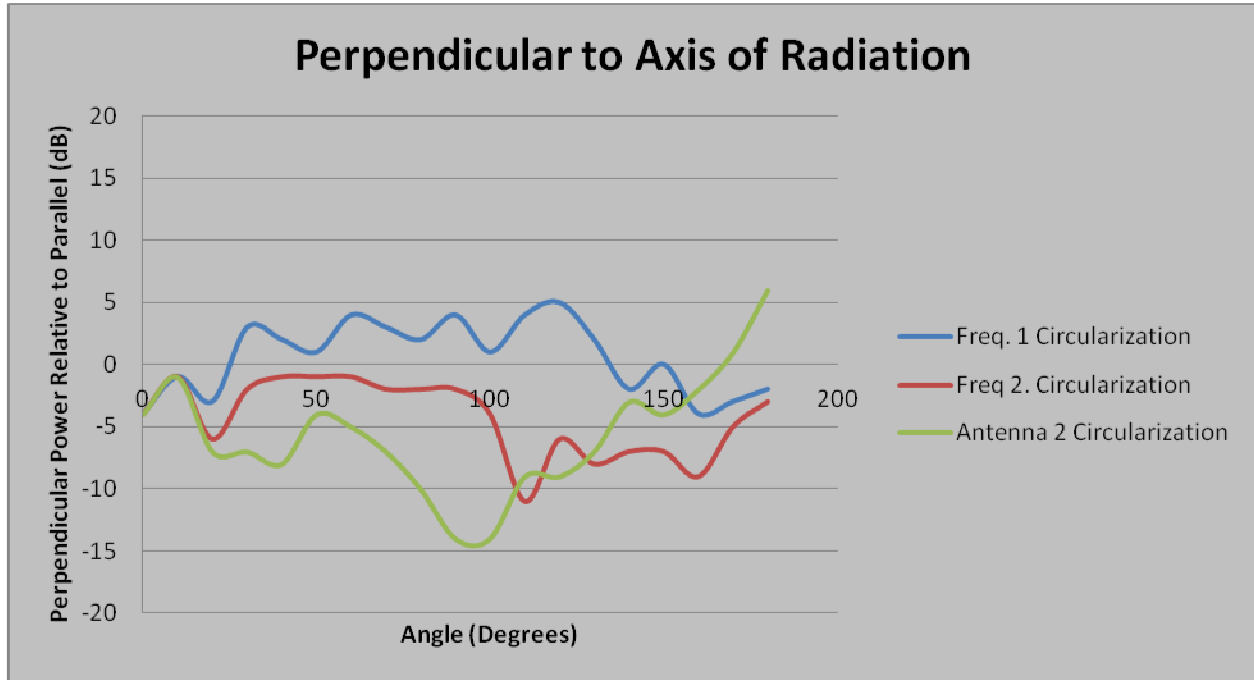

Figure 29: 360 Degree Measurement (Truncated to 180 Degrees) Circularity Graph

The plot below shows the same data but as measured in the 180 direct parallel to the axis of excitation.

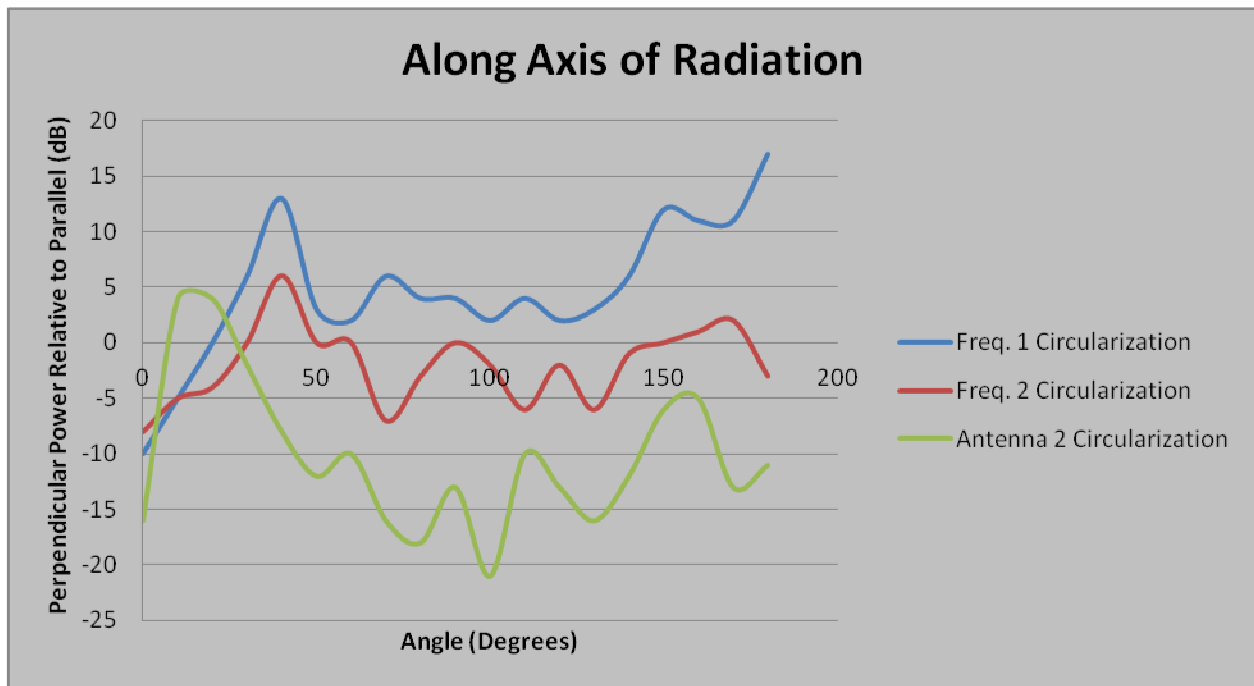

Figure 30: 180 Degree Measurement Circularity Graph

Because of the inconsistent nature of the values, graphs were made representing the average amount of circularity. Below is a plot showing the average circularity as measured in the 360 direction perpendicular to the axis of excitation.

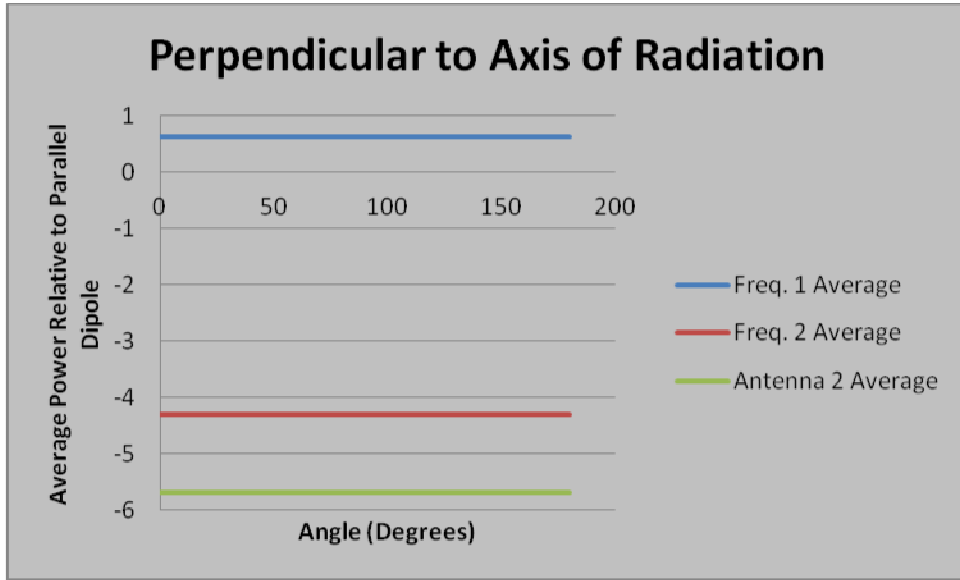

Figure 31: Circularity Average Graph – 360 Degree Measurement

Below is a plot showing the same data but as measured in the 180 degree plane parallel to the axis of excitation.

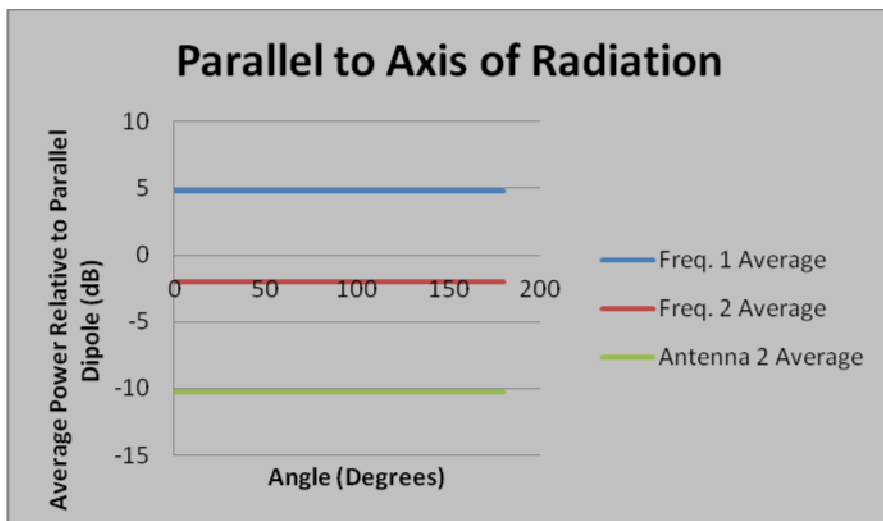

Figure 32: Circularity Average Graph – 180 Degree Measurement

Conclusions

Several important conclusions can be drawn from my results. First, there was the obvious fact that the antenna with the larger cutout was more circularly polarized than the antenna with a small cutout.

Several reasons exist for this conclusion. First, the return loss measurement of this antenna clearly showed two frequencies radiating from this antenna. This was a strong indicator of circular polarization. The second antenna, with the smaller cutout, did not have a measurable second frequency at which it radiated.

The second reason is that looking at the amount of circularity, either with the polar radiation plots, the circular difference plots, or the average circular difference plots, in every case the second antenna radiated a lot less power as measured by the dipole in the perpendicular direction. It is most clear in Figure 32 in which one can see that the average difference in power as measured from the second antenna was 8 dB below the power difference of the second frequency on the first antenna, and a full 15 dB below the power difference for the first frequency on the first antenna.

This means that the first frequency radiated approximately 31 times the power in the perpendicular direction (using the parallel power as a baseline) and the second frequency radiated approximately 6.3 times the power in the perpendicular direction compared to the power radiated in the perpendicular direction by the second antenna.

Unfortunately there is not enough data to establish a mathematical relationship between the size of the cutout and the amount of circularization. However it is clear that the larger cutout produced more circularization. In fact, the first frequency was almost over circularized, in that there was more power measured in the perpendicular direction, on average, than there was in the parallel direction. The closest to being perfectly circular was the second frequency (the main frequency of 1.5 GHz) on the first antenna, which on average was -4dB below the parallel power in the 360 degree measured direction and -2dB below the parallel power in the 180 degree measured direction.

There was a lot of room for measurement error in these results. The room was noisy and the waveforms on the network analyzer were erratic and difficult to accurately measure. Additionally, the accuracy of the network analyzer itself is in question, due to the fact that it was

last calibrated over 12 years ago. However, despite all of this, the results are clearly consistent, especially when it comes to the double frequency seen on the first antenna. That antenna was more circularized than the second antenna.

The radiation patterns were also consistent. They clearly show a roughly spherical radiation pattern centered around the 90 degree line extending directly out from the center of the patch. In addition in many of the plots it can almost be seen that there is a pinching affect near the ground plane, though this is less conclusive. A more accurate measurement would need to be made of such an antenna.

Finally, an additional source of error was the fact that the ground plane used was not infinite in size. It was large, but not large enough to be considered approximately infinite. This can be demonstrating by looking at the back 180 degrees of some of the plots in which it can be seen that there are some side lobes of radiation behind the antenna. Ideally this would not be the case for an infinite ground plane.

Further Work

For future experiments, I would do several things differently. First, the construction of the antennae should be more consistent. With the proper equipment I would solder the antenna plane to the center pin of the connector, in order to create more consistent contact. Additionally, the spacers used need to be of more consistent height. Lastly, I would use a solid layer of cardboard or something similar behind the ground plane in order to keep the copper from warping.

In terms of the experiment, there are two main things I would do differently or improve upon. First, the measurements need to be made in a more radiation free environment. This would be difficult to achieve. Another way to mitigate this would be to take more readings with the equipment in different orientations and then to average the results.

The second thing I would improve upon is the use of different sized antennae. I would create at least a third antenna with no corner cut out to use as a control measurement. I would also create more antennae with different sized cutouts in order to attempt to establish (or verify)

a more consistent relationship between the size of the cutout and the amount of circularity in the radiation pattern.

References

- [1] *Antenna patterns and their meaning*. (n.d.). Retrieved from http://www.cisco.com/en/US/prod/collateral/wireless/ps7183/ps469/prod_white_paper0900aecd806a1a3e.html
- [2] Bancroft, R. *Circular polarized rectangular microstrip antenna design*. Retrieved from http://images.books24x7.com/bookimages/id_14092/fig2-15.jpg
- [3] Fiedziuszko, J. S., Curtis, A. J., Holme, S. C., & Kwok, R. S. (1996). Low loss multiplexers with planar dual mode hts resonators. *IEEE TRANSACTIONS ON MICROWAVE THEORY AND TECHNIQUES*,44(7), Retrieved from http://www.engr.sjsu.edu/rkwok/Publications/mux_IEEE_MTT_44_p1248_1996.pdf
- [4] Miranda, H. (2007 , Spring). *Patch antenna design*. Retrieved from https://ccnet.stanford.edu/cgi-bin/course.cgi?cc=ee144&action=handout_download&handout_id=ID11797377905639
- [5] *Microstrip (patch) antennas*. (2011). Retrieved from <http://www.antenna-theory.com/antennas/patches/antenna.php>
- [6] Ulaby, F. (2005). *Electromagnetics for engineers*. Upper Saddle River, NJ: Pearson Education Inc.

Appendix A – Measurement Data

(all measured values in relative dB)

Table 4: Antenna 1 Measurements – 360 Degree

	Antenna 1					
	f1: 1.28 GHz	f2: 1.504 GHz	f1: 1.28 GHz	f2: 1.504 GHz	f1: 1.28 GHz	f2: 1.504 GHz
	Parallel	parallel	perpendic	perpendic	circular	circular
0	-42	-40	-46	-44	-4	-4
10	-42	-40	-43	-41	-1	-1
20	-42	-36	-45	-42	-3	-6
30	-41	-35	-38	-37	3	-2
40	-35	-32	-33	-33	2	-1
50	-33	-30	-32	-31	1	-1
60	-32	-29	-28	-30	4	-1
70	-32	-28	-29	-30	3	-2
80	-30	-29	-28	-31	2	-2
90	-30	-29	-26	-31	4	-2
100	-29	-30	-28	-34	1	-4
110	-31	-29	-27	-40	4	-11
120	-35	-30	-30	-36	5	-6
130	-34	-31	-32	-39	2	-8
140	-35	-35	-37	-42	-2	-7
150	-41	-38	-41	-45	0	-7
160	-40	-39	-44	-48	-4	-9

170	-40	-41	-43	-46	-3	-5
180	-43	-45	-45	-48	-2	-3
190	-45	-47	-43	-50	2	-3
200	-49	-48	-43	-49	6	-1
210	-62	-50	-46	-50	16	0
220	-62	-54	-48	-49	14	5
230	-61	-60	-53	-52	8	8
240	-57	-57	-48	-62	9	-5
250	-54	-56	-47	-62	7	-6
260	-62	-57	-44	-67	18	-10
270	-56	-58	-45	-58	11	0
280	-49	-57	-47	-53	2	4
290	-50	-50	-45	-56	5	-6
300	-55	-49	-54	-59	1	-10
310	-54	-48	-57	-61	-3	-13
320	-57	-55	-43	-65	14	-10
330	-51	-52	-43	-54	8	-2
340	-44	-46	-48	-56	-4	-10
350	-45	-44	-50	-50	-5	-6

Table 5: Antenna 1 Measurements – 180 Degrees

	Antenna 1					
	f1: 1.28 GHz	f2: 1.504 GHz	f1: 1.28 GHz	f2: 1.504 GHz	f1: 1.28 GHz	f2: 1.504 GHz
	Parallel	parallel	perpendic	perpendic	circular	circular
0	-40	-45	-50	-53	-10	-8
10	-40	-41	-45	-46	-5	-5
20	-39	-39	-39	-43	0	-4
30	-37	-37	-31	-37	6	0
40	-42	-40	-29	-34	13	6
50	-31	-32	-28	-32	3	0
60	-27	-32	-25	-32	2	0

70	-32	-27	-26	-34	6	-7
80	-29	-29	-25	-32	4	-3
90	-30	-31	-26	-31	4	0
100	-27	-31	-25	-33	2	-2
110	-28	-27	-24	-33	4	-6
120	-28	-32	-26	-34	2	-2
130	-29	-28	-26	-34	3	-6
140	-37	-34	-31	-35	6	-1
150	-44	-38	-32	-38	12	0
160	-44	-42	-33	-41	11	1
170	-48	-45	-37	-43	11	2
180	-58	-42	-41	-45	17	-3

Table 6: Antenna 2 Measurements – 360 Degrees

Antenna 2		f: 1.556 GHz		circular	
f: 1.556 GHz		f: 1.556 GHz		circular	
Parallel		perpendic		circular	
0	-44	-48	-4		
10	-43	-44	-1		
20	-36	-43	-7		
30	-34	-41	-7		
40	-34	-42	-8		
50	-31	-35	-4		
60	-28	-33	-5		
70	-27	-34	-7		
80	-26	-36	-10		
90	-29	-43	-14		
100	-28	-42	-14		
110	-29	-38	-9		
120	-30	-39	-9		
130	-32	-39	-7		
140	-36	-39	-3		

150	-38	-42	-4
160	-41	-43	-2
170	-45	-44	1
180	-51	-45	6
190	-48	-46	2
200	-46	-47	-1
210	-56	-48	8
220	-53	-54	-1
230	-57	-61	-4
240	-57	-62	-5
250	-66	-56	10
260	-57	-74	-17
270	-58	-61	-3
280	-55	-57	-2
290	-57	-61	-4
300	-52	-64	-12
310	-55	-69	-14
320	-53	-58	-5
330	-51	-57	-6
340	-45	-55	-10
350	-42	-52	-10

Table 7: Antenna 2 Measurements – 180 Degree

Antenna 2
f: 1.556

f: 1.556

	GHz
	Parallel
0	-52
10	-49
20	-52
30	-46
40	-44
50	-40
60	-35
70	-32
80	-30
90	-28
100	-26
110	-27
120	-27
130	-25
140	-28
150	-33
160	-33
170	-32
180	-42

GHz
perpendic
-68
-45
-48
-48
-52
-52
-45
-48
-48
-41
-47
-37
-40
-41
-40
-39
-38
-45
-53

circular
-16
4
4
-2
-8
-12
-10
-16
-18
-13
-21
-10
-13
-16
-12
-6
-5
-13
-11